

AKUSENSE

Vision sensor The VDS 10 series manual of operation



V1.2

Catalogue

Chapter 1: Product Introduction	3
1.1 Product description	3
1.2 Main characteristics	3
1.3 Appearance introduction	4
1.4 Definition of interface and scatter line	6
1.5 Accessories and dimensions	7
Chapter II Equipment Installation and Operation	8
2.1 Equipment installation	8
2.2 Power supply connection	10
2.3 Communication connection	11
Chapter III IO Electrical Characteristics and Wiring	12
3.1 I / O electrical characteristics	12
3.2 IO external wiring	15
3.3 RS-232 serial port	17
Chapter 4: Client operations	18
4.1 Software Connection	18
4.2 PC network configuration	19
Chapter 5: Function introduction	21
5.1 Introduction of the interface	21
5.2 New scheme	22
5.3 Scheme management	32

Chapter 6 List of FAQ.....	34
6.1 Client software identified the device but showed "inaccessible"	34

Chapter 1: Product Introduction

1.1 Product description

This manual is applicable to Meiji vision sensor VDS 10 series, can be applied to 3C, food, electronic semiconductor, auto parts and other industries. Built-in a variety of depth vision detection tools, equipped with lighting, acquisition, processing, communication and other functions, excellent product performance provides reliable detection results for presence, negative, counting and other anti-error scenarios.

1.2 Main characteristics

- Using innovative embedded hardware platform for high-speed image acquisition and processing
- With a liquid lens, the built-in self-developed focus algorithm, which can achieve high-speed zoom
- Integrating high-precision positioning and detection algorithm can meet the detection requirements of error-proof scenarios such as presence and counting
- IO interface is rich and can communicate with other devices in real time through IO signal
- Support TCP Server, TCP Client, ModBus TCP, MELSEC, SLMP, RS-232, EtherNet / IP and other communication modes for real-time data transmission
- Small volume, suitable for narrow space installation

1.3 Appearance introduction

A appearance description

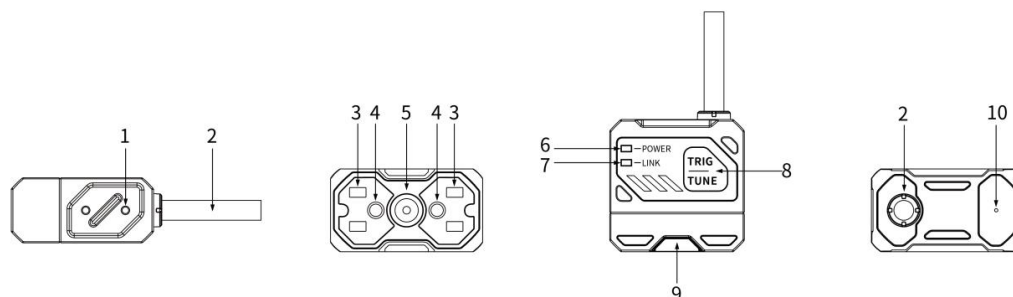

order number	name	description
1	screw	Visual sensor mounting hole for fixing the equipment
2	connecting line	M12-17 PIN cable, including power line, Ethernet cable, IO cable, serial port, function line
3	illuminant	Built-in red / white light source, used to collect the light, to ensure the image effect
4	Sight light	Indicates the center position of the image for easy targeting of the target
5	imaging sensor	It is used to collect images
6	For the POWER, the power supply indicator lamp	The equipment is green for normal operation, no operation
7	The LINK network indicator light	Network communication is normal
8	The TRIG bonds / TUNE bonds	Trigger / one-key adjustment button. A single click for the trigger photo, long press 5s for one-key parameter adjustment
9	Status indicator light	Green light at OK, red light at NG
10	buzzer	Voice cue during decoding success or failure

B. Description of the status indicator light

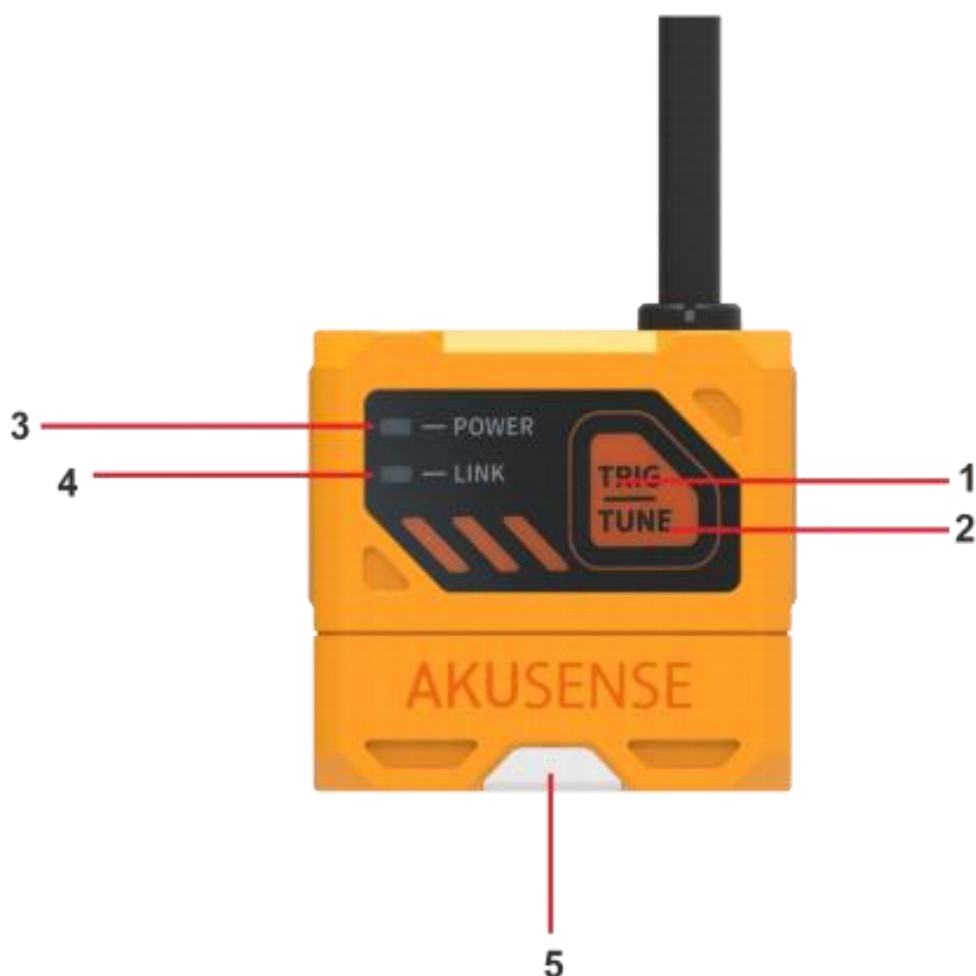

order number	name	description
1	TRIG key	Trigger the button
2	TUNE key	Automatic reference button
3	power light	The device is turned green for normal operation
4	Network indicator light	Network communication is normal
5	Status indicator light	Green light at OK, red light at NG

1.4 Definition of interface and scatter line

The equipment interface is M12-17 PIN interface, and the specific pin signal definition is shown in the following figure.

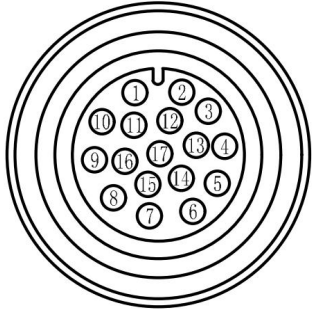

When wiring the equipment, please connect according to the pin number in the table and the color on the cable label.

M12-17 PIN header	pin	pigment	signal
	1	red	DC_24V
	2	empty	
	3	empty	
	4	Red and blue	RS232_TXD
	5	pale green	RS232_RXD
	6	Orange white	ENET_RX-
	7	green	ENET_TX+
	8	yellow	LINE_INO
	9	brown	IN_COM
	10	white	LINE_IN1
	11	black	GND
	12	gray	LINE_OUT0
	13	empty	
	14	orange	ENET_RX+
	15	Green white	ENET_TX-
	16	purple	LINE_OUT1
	17	blue	LINE_OUT2

1.5 Accessories and dimensions

A inventory

For the normal use of the equipment, please prepare the supporting items shown in the following table before installation.

Accessories name	description	picture
cable	Connect the M12-17 PIN cable to the device interface	
source	The 24V power supply adapter	
Type L mounting bracket	L-shaped mounting bracket + screws	

B size

单位:mm

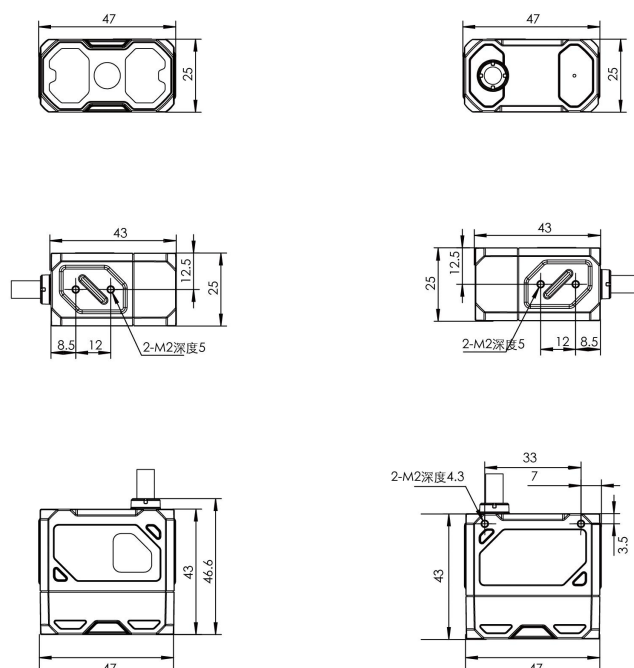

Chapter II Equipment Installation and Operation

2.1 Equipment installation

1. Install the equipment to the fixing bracket with screws, and then to other mechanism parts through the fixing bracket.

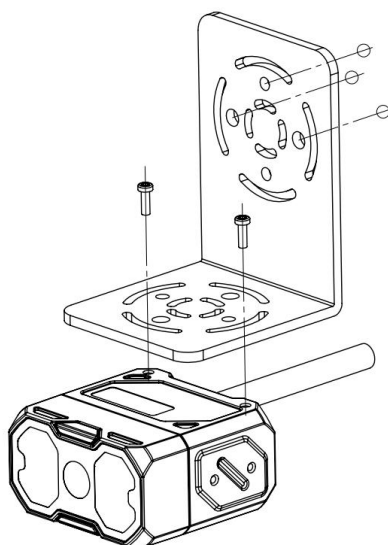

Demo diagram: Front face installation

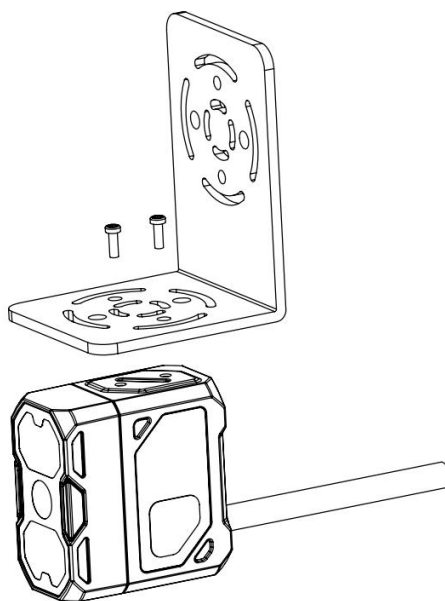

Demonstration diagram: Side installation

2. Install to tilt at 10-15 degrees to avoid spots and reflection.

The liquid zoom sensor is 40mm-300mm

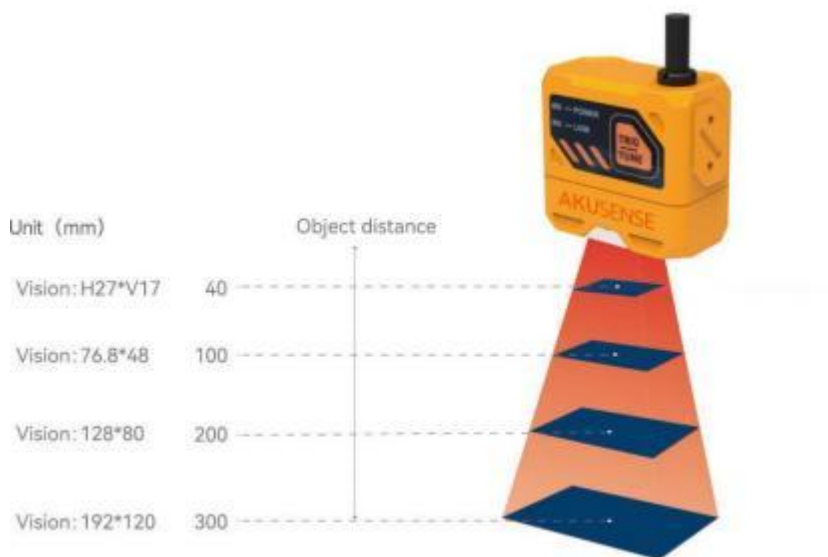

Schematic diagram of the liquid-state zoom sensor installation

The manual zoom sensor working distance is 30mm-300mm

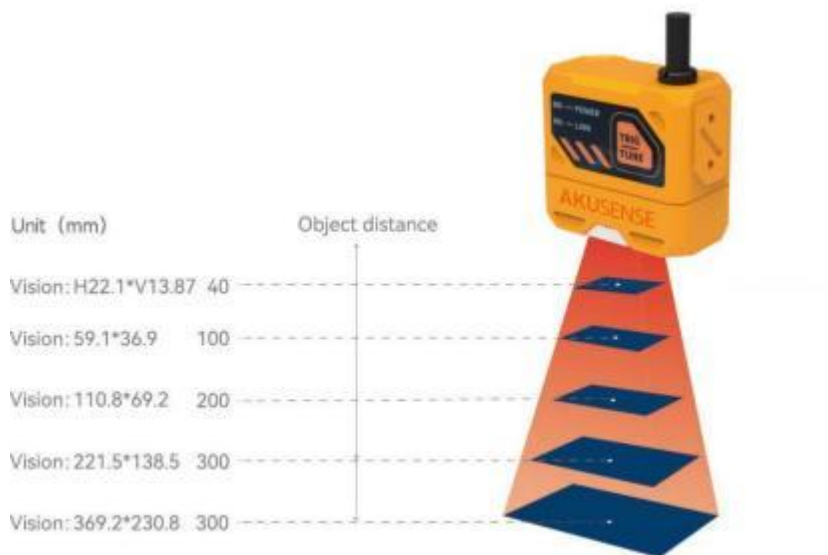

Installation diagram of manual focus sensor

2.2 Power supply connection

Power supply supports 24V DC, up to 3A.

There are two power supply methods: support 24VDC direct connection or 220VAC with adapter connection.

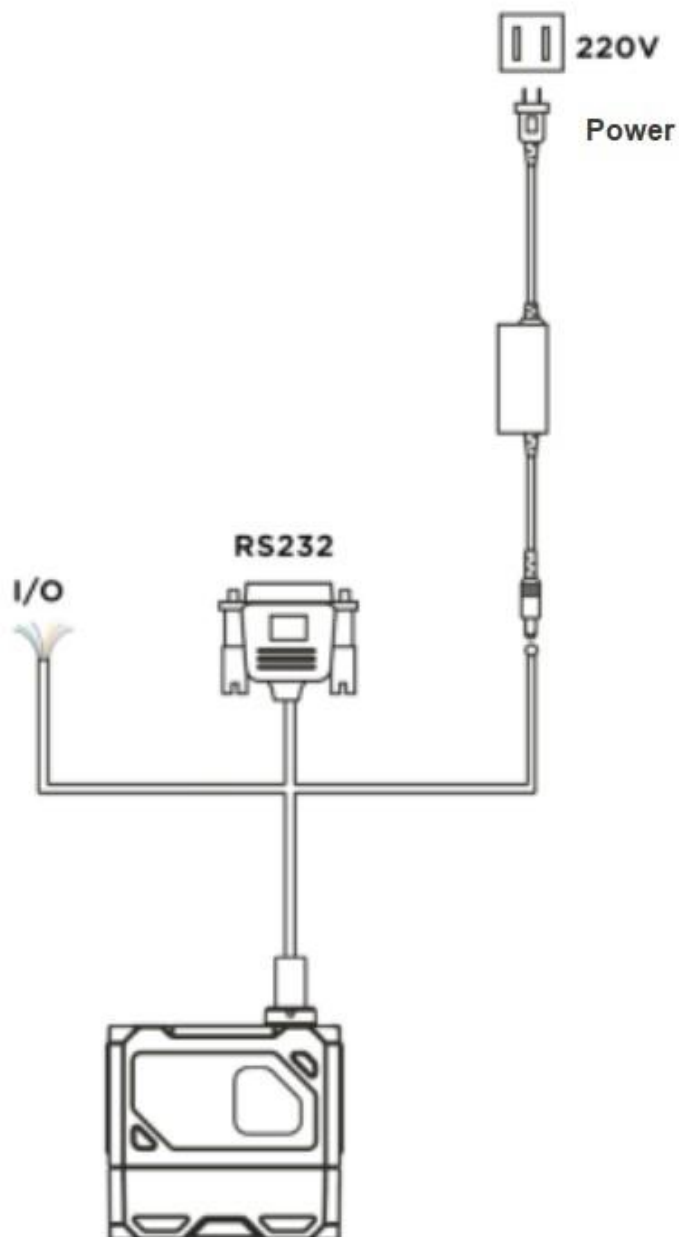

2.3 Communication connection

A RS232 Serial port connection

The default port rate is 9600, check bit: NULL, data bit: 8, termination bit: 1. Actual parameters can be changed when debugging the software.

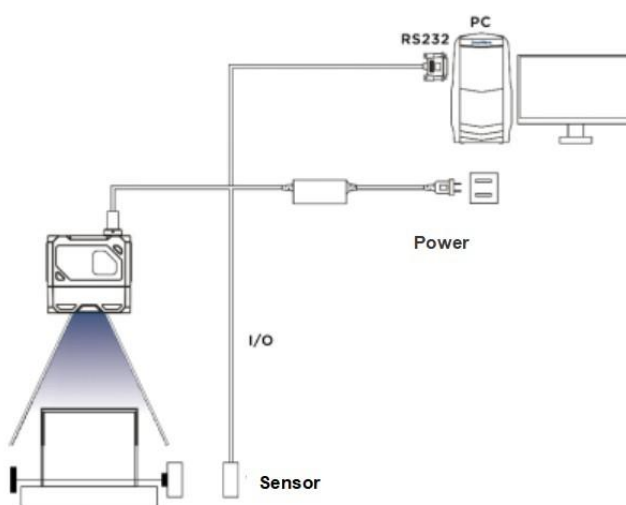

B Ethernet linkage

The default IP address is 169.254.153.0, and the default data port is 15000.

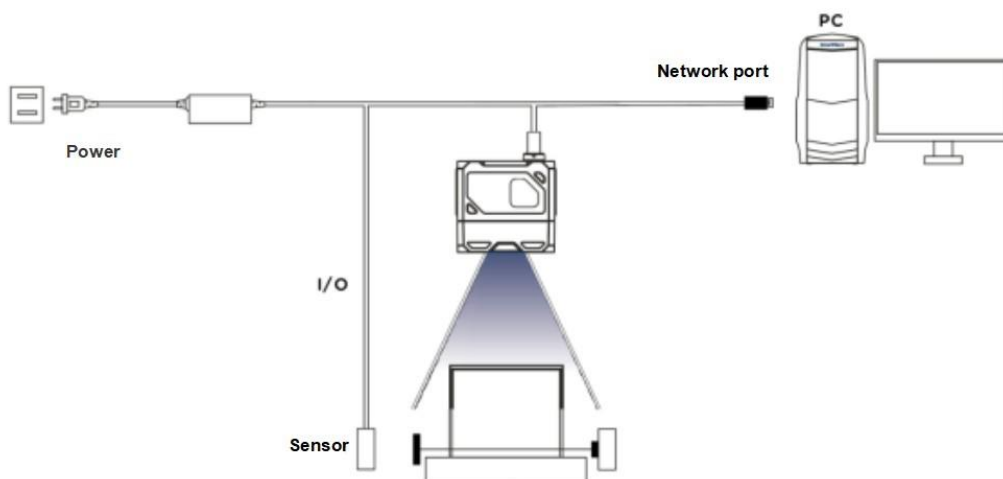

Chapter III IO Electrical Characteristics and Wiring

The visual sensor has two optical-coupled isolated inputs and three non-isolated outputs.

3.1 I / O electrical characteristics

The LineIn 0 / 1 in the device I / O signal is the photocoupled isolation input, and the LineOut0 / 1 / 2 is the non-photocoupled isolation output.

3.1.1 Input electrical characteristics

The parameter name	Parameter symbol	parameter values
Enter the logic to the low level	VOL	8V
Enter the logic high level	VOH	12V
Input drops along the delay	TDF	10 μ s
Input rise edge delay	TDR	47 μ s

*Description *: The input logic is low or logic high, which is the threshold of the voltage representing the input. Input up or down delay is the representative performance.*

3.1.2 Output electrical characteristics

The parameter name	Parameter symbol	parameter values
Output logic is at a low level	VOL	0.7V
Output logic is at a high level	VOH	23.9V
Output drops along the delay	TDF	20.3 μ s
Output rises along the delay	TDR	550 μ s
Output drop time	TF	12 μ s
Output up time	TR	3.5 μ s

3.1.3 Input the internal wiring diagram

- incoming signal

In 0 / 1 in the device I / O signal is the input, and the input voltage ranges from 8 to 24 VDC.

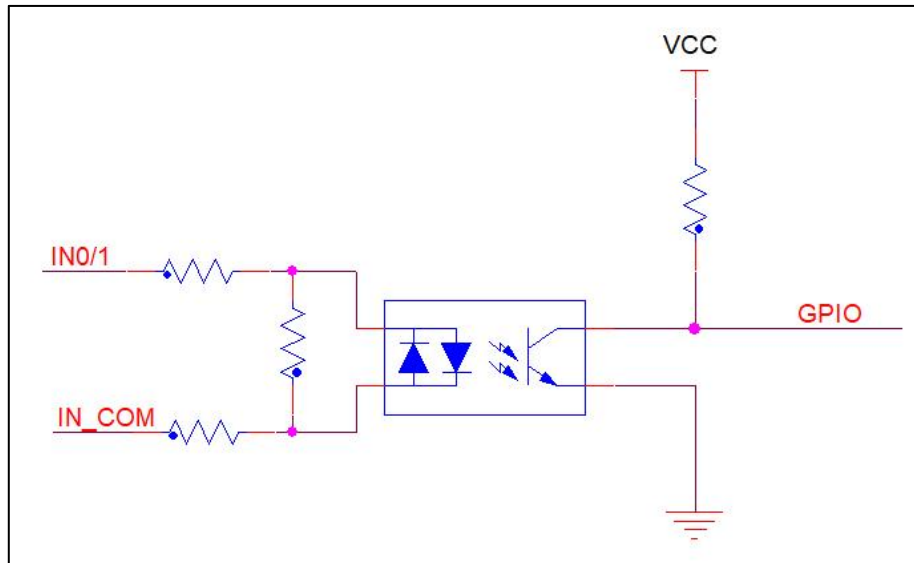

Equipment input circuit diagram

- The input logic level is:

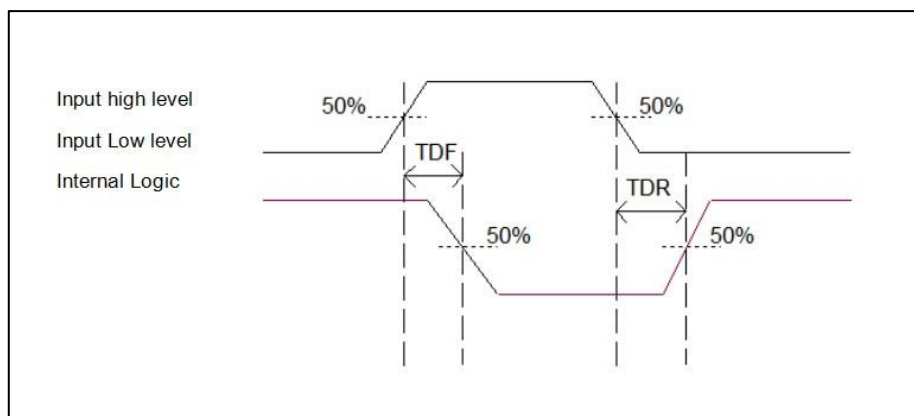

Enter a logical level diagram

3.1.4 Input the internal wiring diagram

- output signal

The Lineout0 / 1 / 2 in the device I / O signal is the output. The output voltage range from 5 to 40 V, and the output current shall not exceed 50 mA.

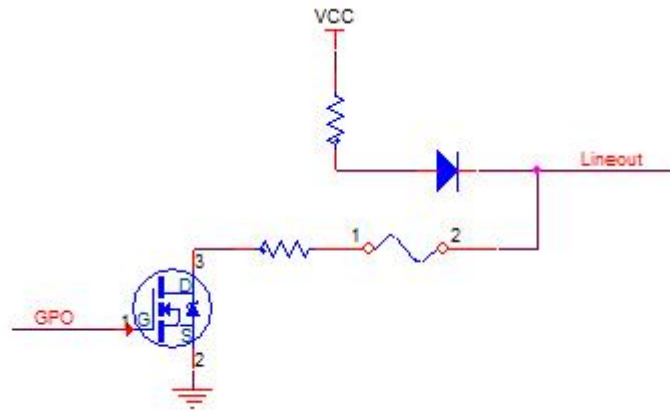

Equipment output circuit diagram

- The output logic level is:

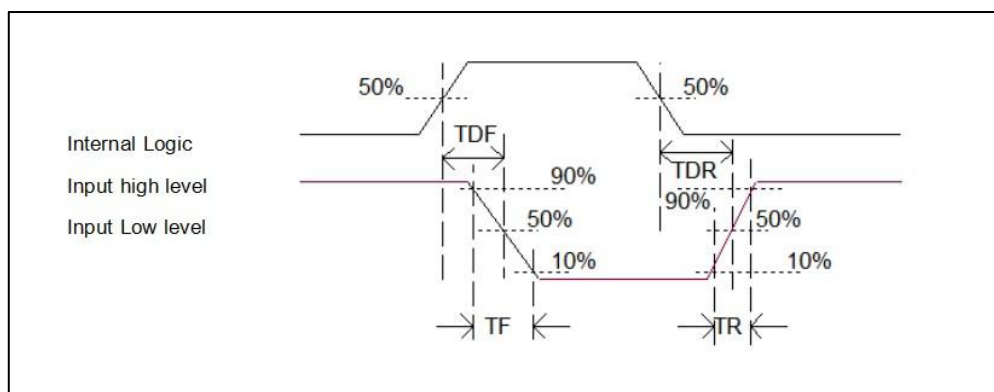

Output logic level diagram

3.2 IO external wiring

The device may receive the external input signal or the output signal to the external device through the I / O interface. This section mainly introduces how to connect the I / O part.

The signal input in the wiring diagram takes LineIn 0 as an example, and the signal output takes LineOut 0 as an example. Other interfaces can be similar according to the cable definition in the wiring diagram and combined with the interface introduction.

3.2.1 Input the external wiring diagram

Different types of equipment, equipment input wiring is different.

- The input signal is the NPN

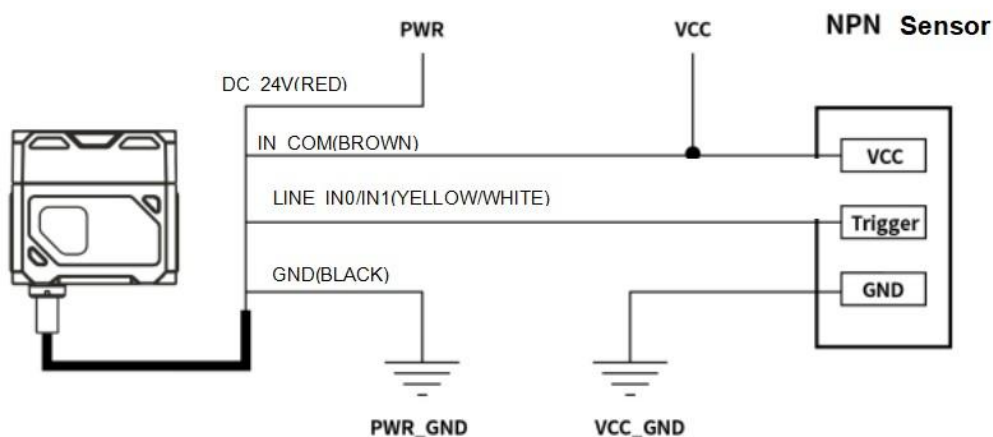

- The input signal is the PNP

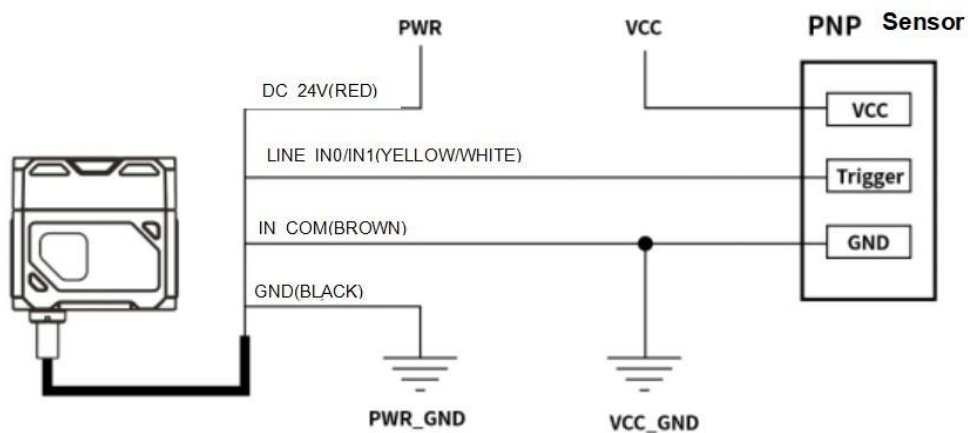

3.2.2 Output the external wiring diagram

Different types of equipment have different output wiring of the equipment.

- External equipment is NPN, type equipment

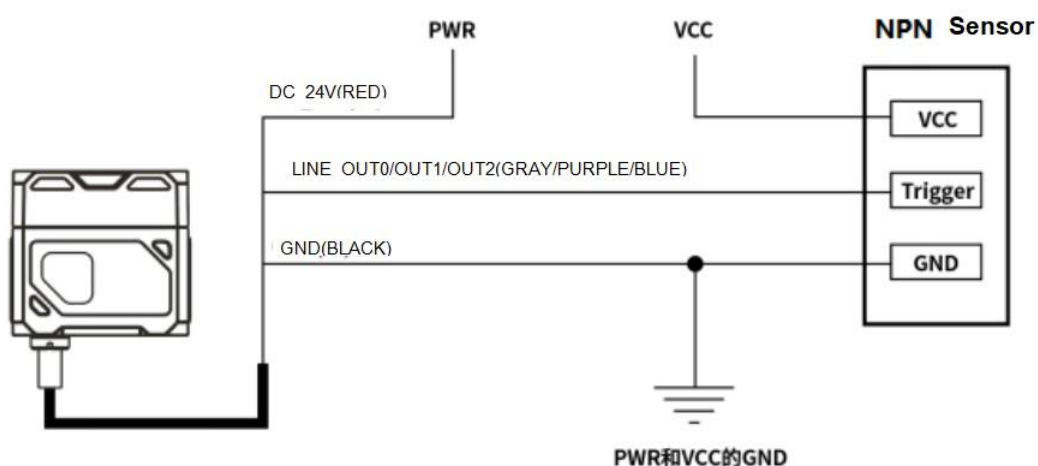

*explain *:*

- 1) The voltage value of the VCC of the equipment shall not be higher than the voltage value of the sensor PWR, otherwise the output signal of the equipment will be abnormal.
- 2) The output load current shall meet the product specifications (serial flow resistance if necessary).

3.3 RS-232 serial port

The device supports the RS-232 serial port output.

3.3.1 RS-232 serial port

The common oral definition of the 9-pin header 232 serial port connector string is shown in the figure below.

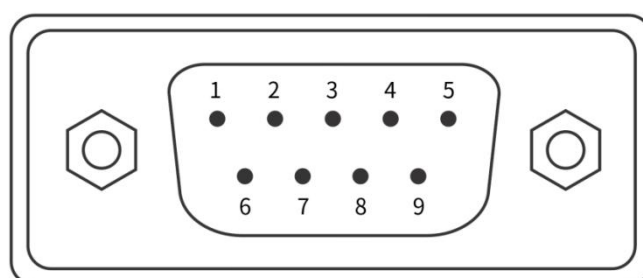

9-pin, header connector

Pin number	meaning	function description
2	RX	Receive data
3	TX	Send data
5	GND	Signal ground

9-pin header 232 serial port definition

*Note *: The voltage value of VCC shall not be higher than that of PWR, otherwise the output signal of the equipment will be abnormal.*

Chapter 4: Client operations

4.1 Software Connection

- Double-click on the icon to open the software;
- The vision sensor and the PC of the configuration software need to be connected in the same network segment;
- Default IP address: 169.254.153.5; Gateway 255.255.255.0;
- You can use the DHCP and use the static IP address form to make the connectivity successful.

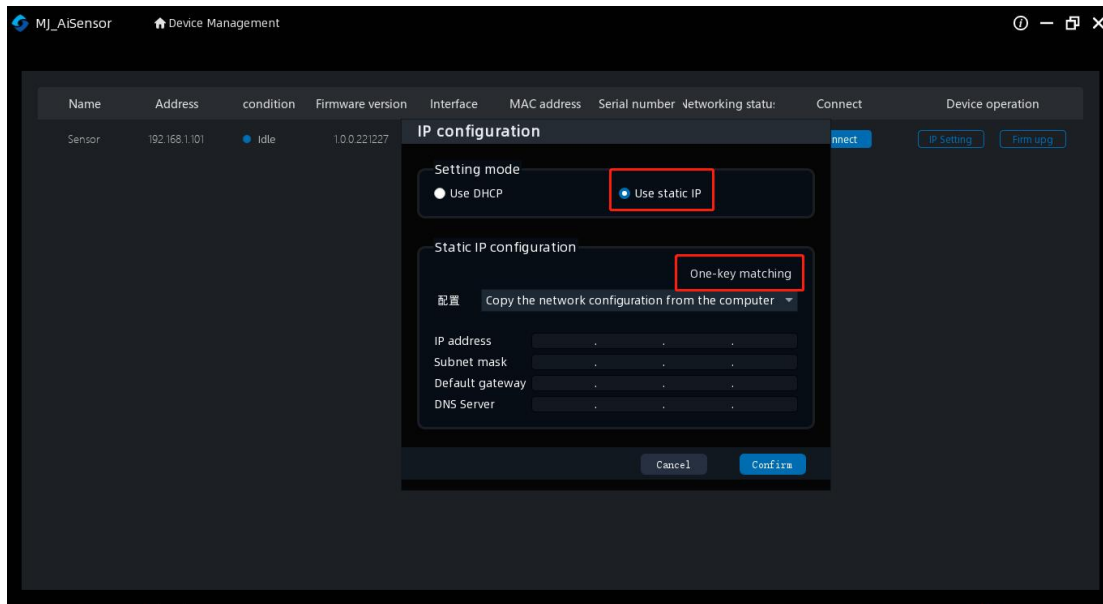

revise IP

4.2 PC network configuration

4.2.1 Change the IP address of the PC

The operation steps are as follows: 1) Take Windows10 as an example, turn "Start menu"> "Settings"> "Network and Internet", ">" Ethernet ">" More Adapter Options ">" Ethernet 3 ">" Right-click "Properties"> "Network"> "Internet Protocol Version 4 (TCP / IPv4)", the IP address of the corresponding PC is 169.254.153.5; subnet mask: 255.255.255.0.

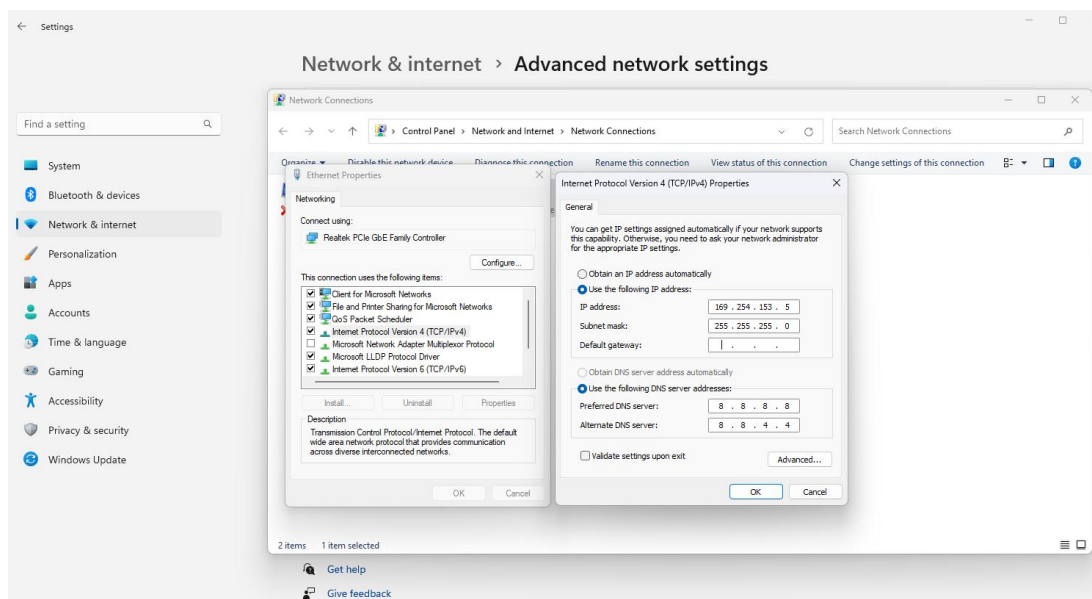

2) Open the configuration software, select the corresponding PC and click the connection to complete.

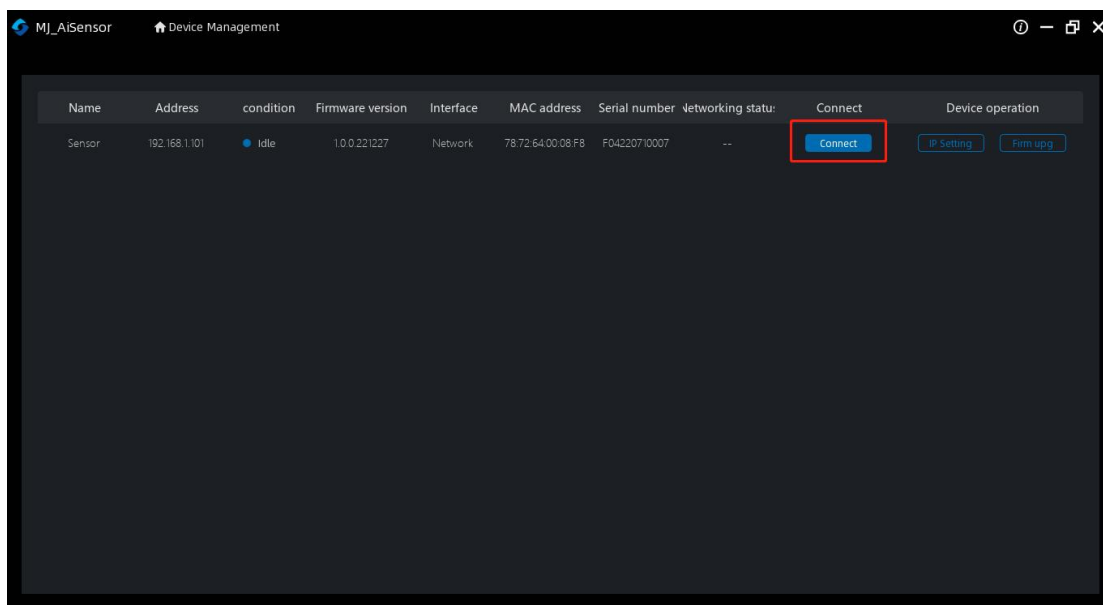

4.3.2 Change the sensor IP address

The operation steps are as follows: open the configuration software, select the corresponding PC network card, display the sensor, click IP Settings> Use static IP> One-click Match> confirmation, change the IP address to the same network segment IP as the PC.

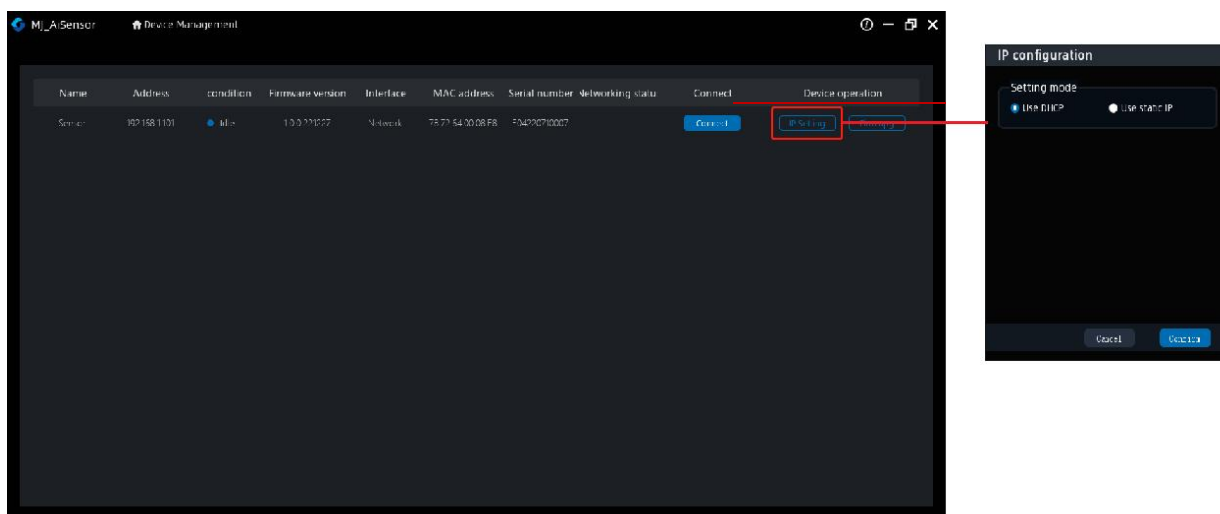

Chapter 5: Function introduction

5.1 Introduction of the interface

The device can operate through the client, specifically as follows:

- 1) Ensure that the device is accessible, and click the "Connect" of the client.
- 2) After connecting the device, the main interface of the client is shown in the following figure. See the table for the introduction of each functional module.

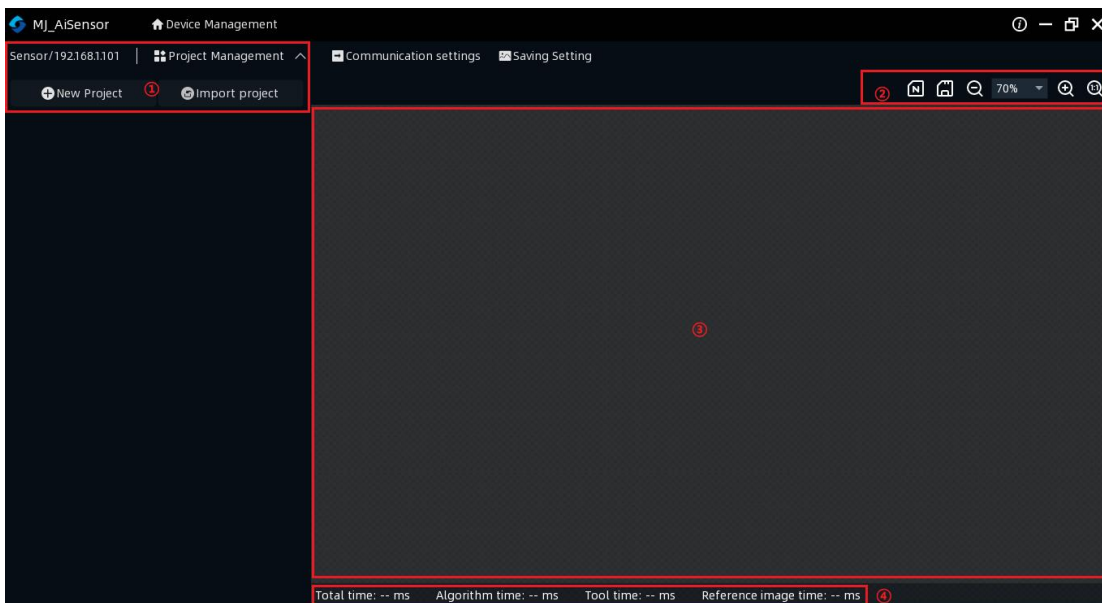

order number	name	Brief description of function
1	Scheme bar	Basic management of the configuration scheme on the client interface. Including new scheme, import scheme, etc
2	Preview the window toolbar	The image of the preview window can be enlarged, reduced, and displayed in proportion
3	Preview window	It can preview the currently collected images of the device, the algorithm to read, and draw the effect of the ROI window.
4	Time-consuming display	Display the processing time of the device currently processing images. Including: overall time consuming, algorithm time consuming, tool time consuming, reference map time consuming

5.2 New scheme

5.2.1 Camera debugging

It includes three items: camera parameter setting, camera trigger setting and parameter expansion.

5.2.1.1 Camera parameter settings

Camera parameter setting: click to adjust, can adjust the brightness, white balance, focus, make the image clearer.

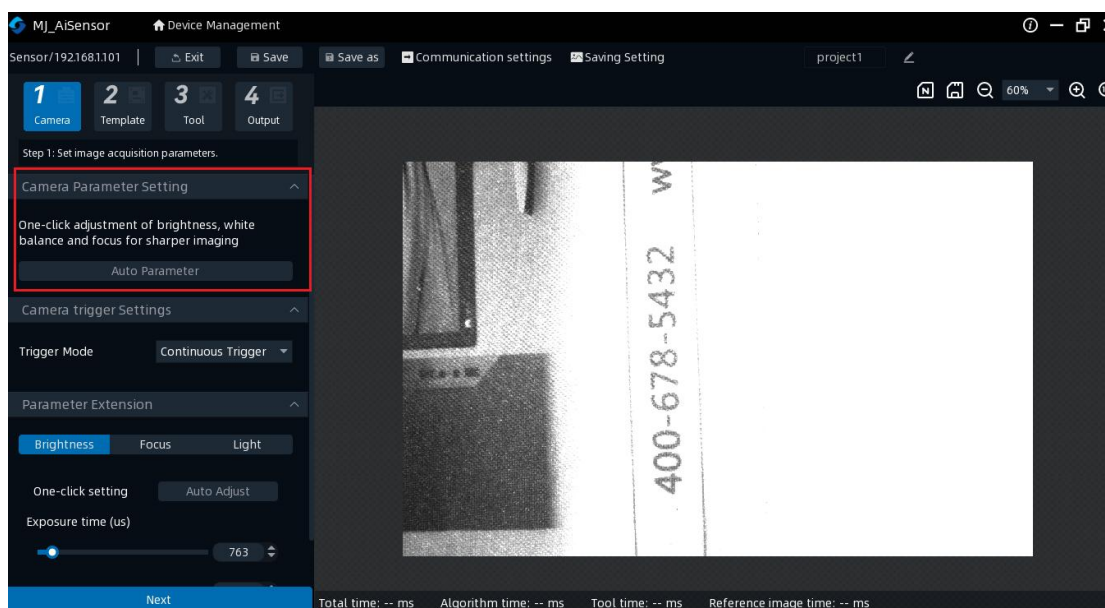

5.2.1.2 Camera trigger settings

Camera trigger settings: "continuous trigger", "software trigger", "IO trigger", three trigger ways.

Continuous trigger: Continuous trigger means that the sensor continuously triggers to take a photo, and the trigger mode can be set directly on the software side.

Software trigger: Software trigger means that the sensor triggers a photo after receiving the signal from the software.

IO trigger: an IO trigger indicates that the sensor triggers a photo after receiving the signal. This trigger mode requires set after selecting Single (External) mode.

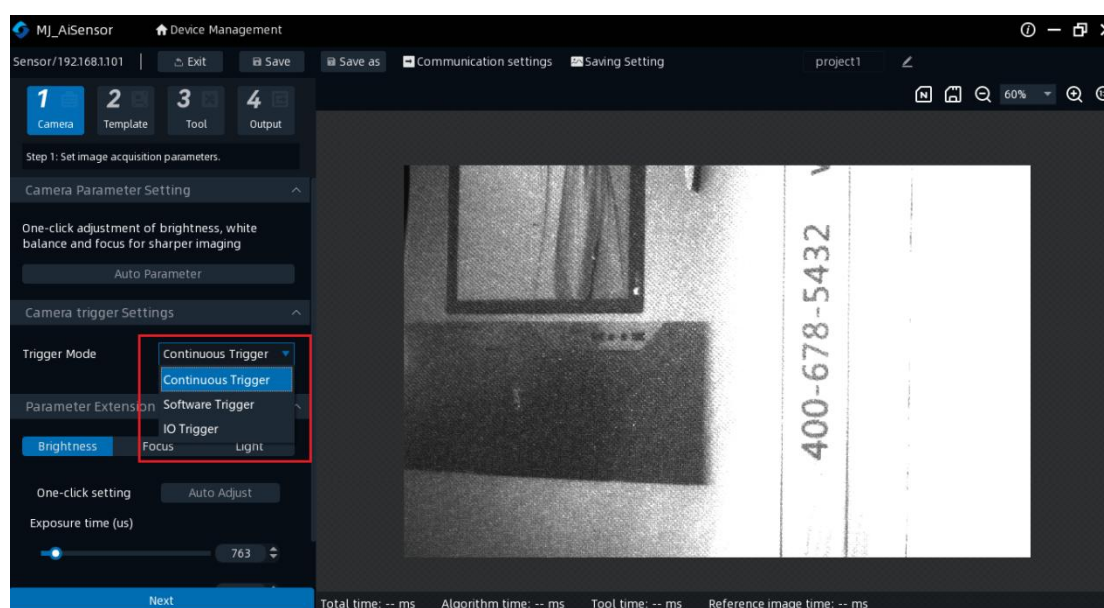

5.2.1.3 and the parameter extension

The parameter extension includes: adjusting the brightness, adjusting the focus, and adjusting the lighting

Adjust the brightness: you can pull the brightness standard adjustment axis to adjust the brightness of the camera from low to high

Exposure time: the exposure time of the camera can be adjusted in the range of 20-2000, and the exposure time can be adjusted by pulling the horizontal axis. You can also write a specific exposure value directly in the input box

One-button setting: you can adjust the brightness, exposure time, gain and other parameters with one button

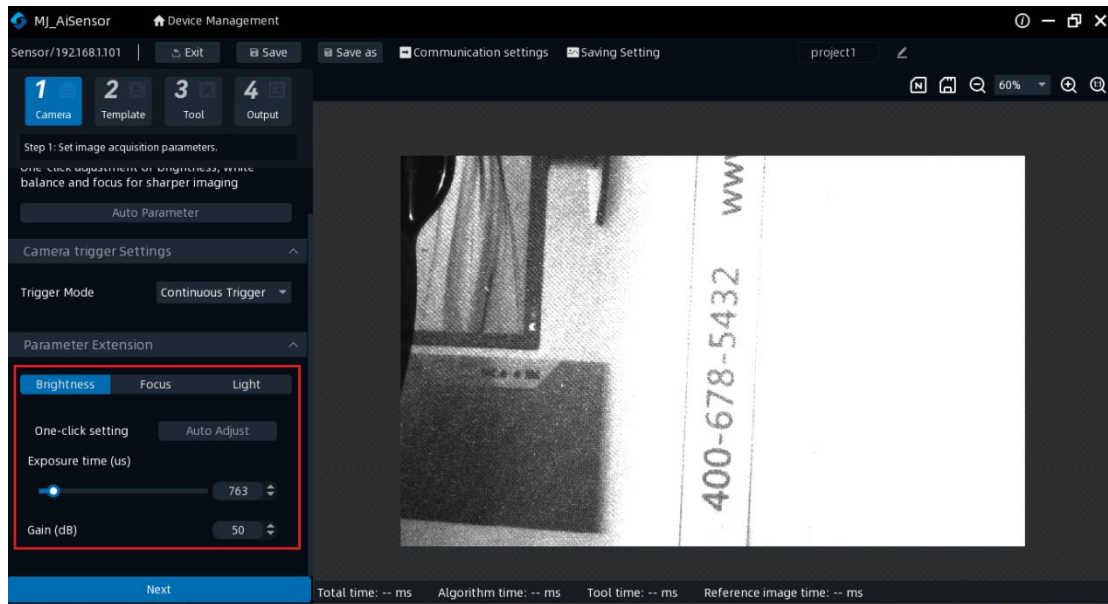

Adjust the focus: the focus value can be adjusted to reach a clear state. The values of the regulatory focus were all adjustable at 1 – 1023.

Adjustment mode: you can pull the horizontal axis of the adjustment position, input the value in the box, and click the upper and lower triangle arrow to adjust.

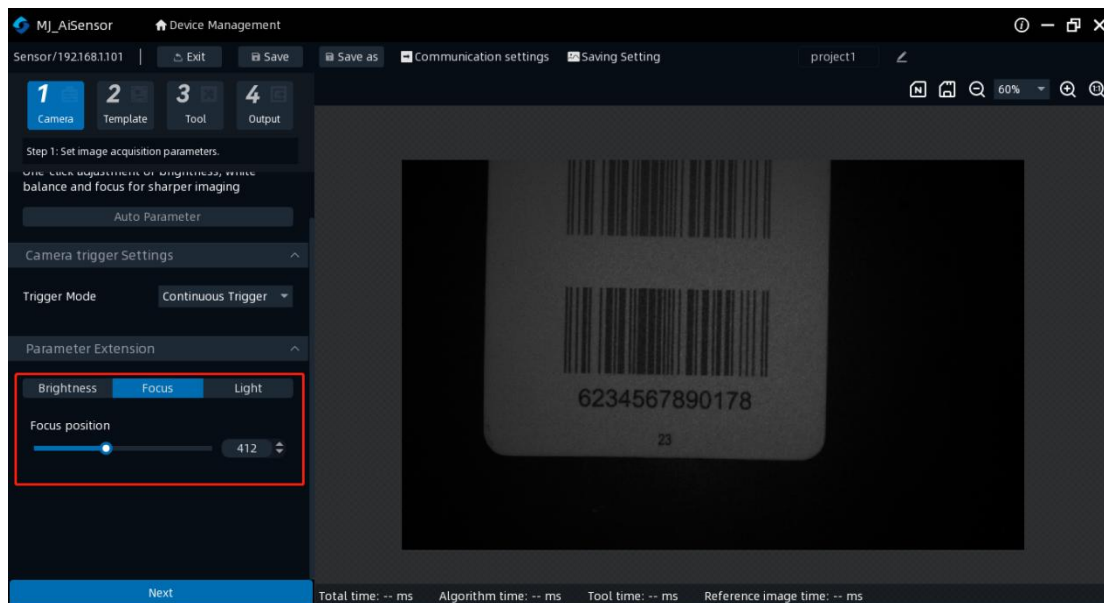

5.2.2 Template addition

Step 2 is to add the template and add the reference image.

Click "+ Template Reference Image" to add the reference image of the template

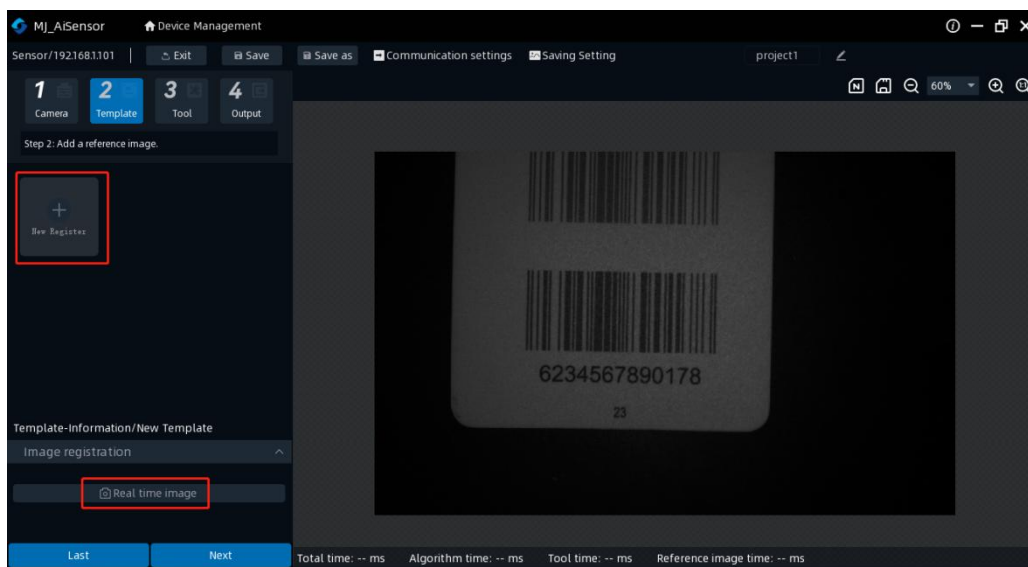

5.2.2.1 Image registration

Image registration: You can create a new image for the template.

Click "Real-time Image" to select taking photos to determine whether to set the current image as a template.

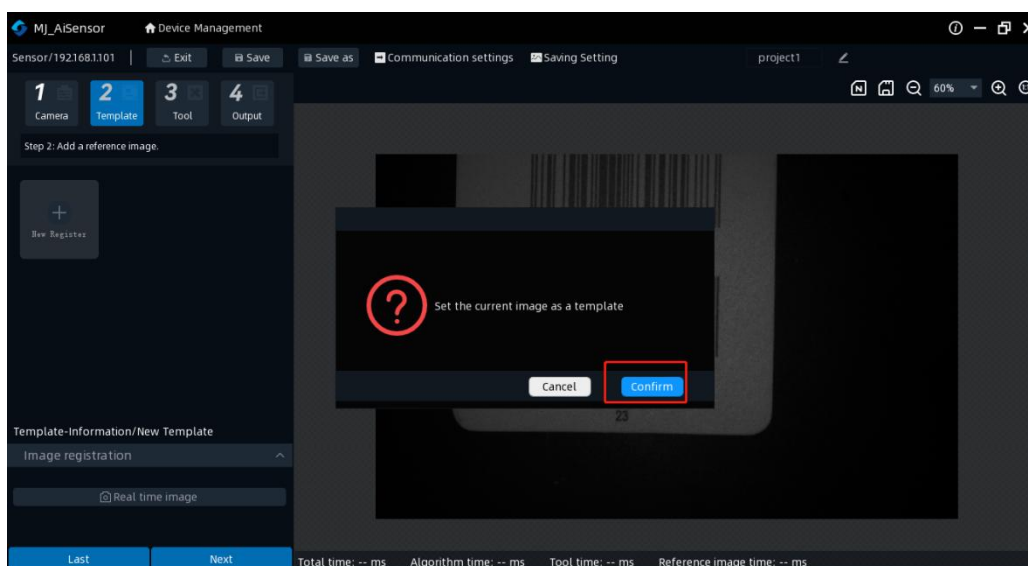

5.2.3 Tool Settings

Step 3: Select a template and add tools to set up your tasks.

Click "+ tool" to add 4 algorithm tools: position correction, with or without tool, counting tool, and pattern tool

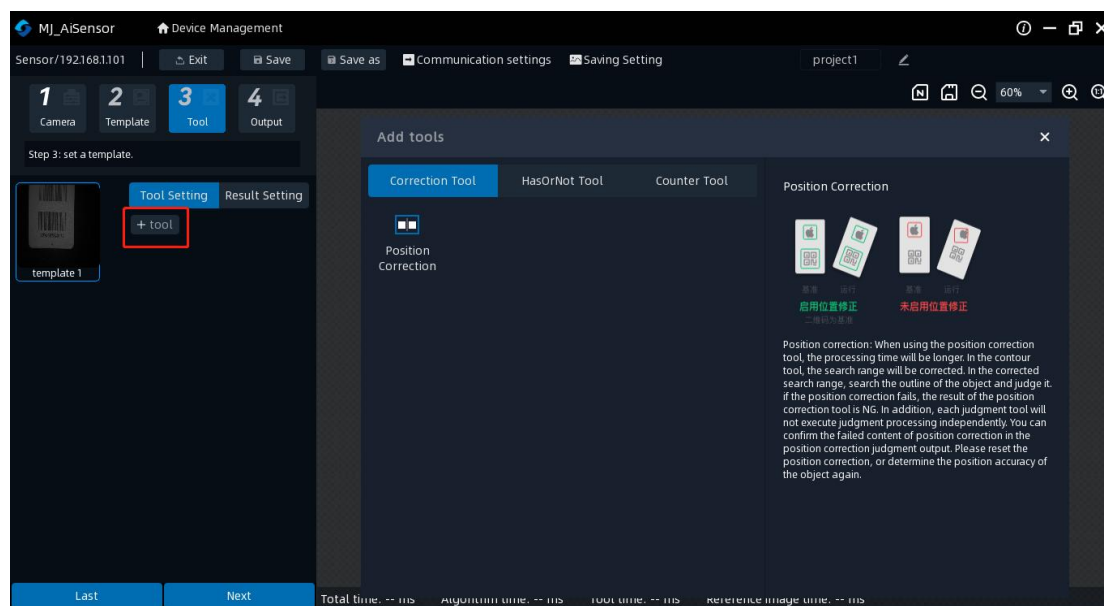

5.2.3.1 Position correction

Position correction: The processing time becomes longer when using the position correction tool. In the profile tool, the search range is position-corrected. Within the corrected search range, the outline of the object is searched and judged. If the position correction fails, the position correction tool is NG. In addition, each judgment tool does not perform the judgment processing alone. The failure content of the position correction can be confirmed in the position correction judgment output. Please reset the position correction, or redefine the position accuracy of the object item.

Image algorithm tools are divided into: search area, adjust contour, and adjust threshold

Search area: delimit the rectangular box and circle box in the search area, and click "rectangle" or "Circle" to search for the designated area in the preview window

Adjust the outline: the outline is divided into low, middle and third grade. Sliding the coordinate horizontal axis to adjust the contour sensitivity

Adjustment threshold: adjustable similarity

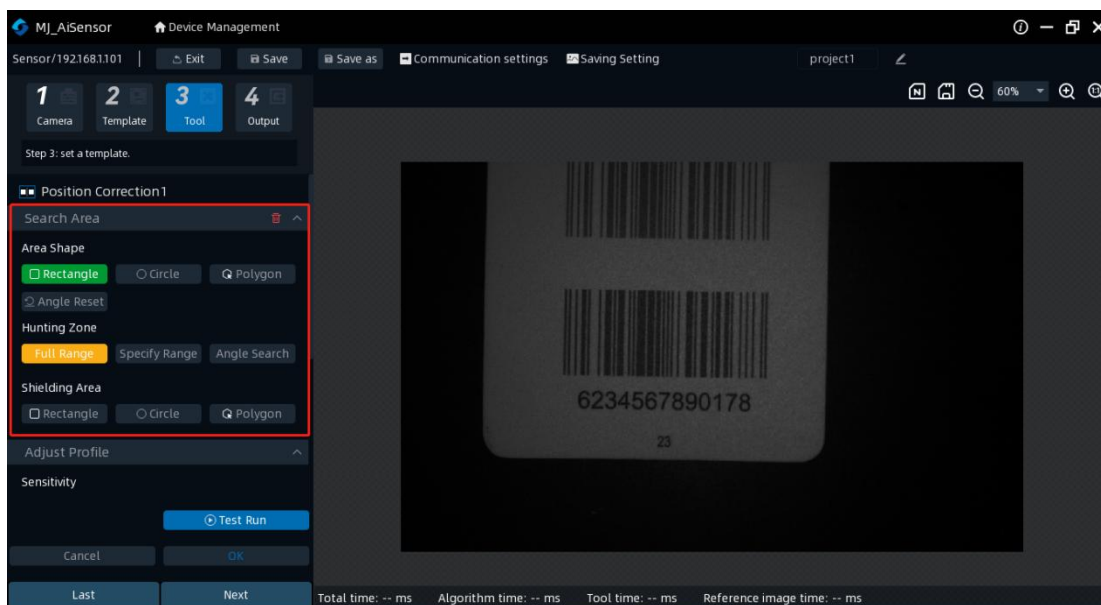

5.2.3.2 Tool or tools

Whether the pattern: determine the presence and similarity of a specific pattern in the set area. OK: A specific pattern was successfully searched in the set area. NG: There is no pattern in the set area, and the pattern similarity is less than the set threshold.

There or no tools are divided into: search area, adjust contour, adjustment threshold

Search area: delimit the rectangular box and circle box in the search area, and click

"rectangle" or "Circle" to search for the designated area in the preview window

Adjust the outline: the outline is divided into low, middle and third grade. Sliding the coordinate horizontal axis to adjust the contour sensitivity

Adjustment threshold: adjustable similarity

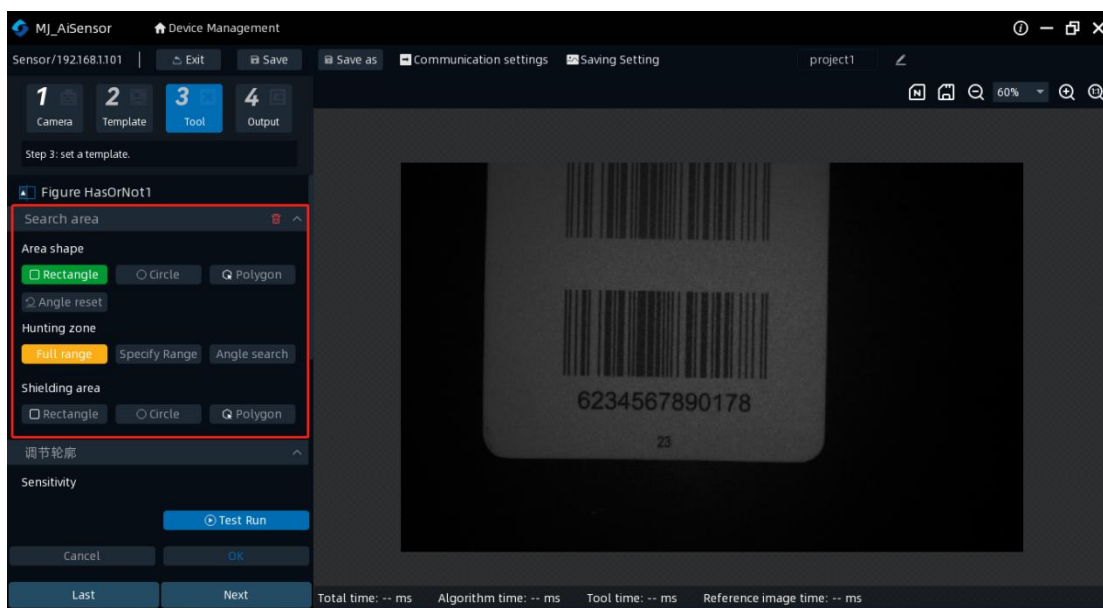

Spot presence: determine the presence and similarity of a specific line in the set area.

OK: The specific spot was successfully searched in the set area. NG: There are no spots in the set area, and the pattern similarity is less than the set threshold.

Search area: delimit the rectangular box and circle box in the search area, and click "rectangle" or "Circle" to search for the designated area in the preview window

Identification setting: Determine the gray scale threshold through the identification setting. The adjustment interval was all adjustable in the 0 – 255 range

Filter tool: it can be adjusted in the range of 0-1000,000

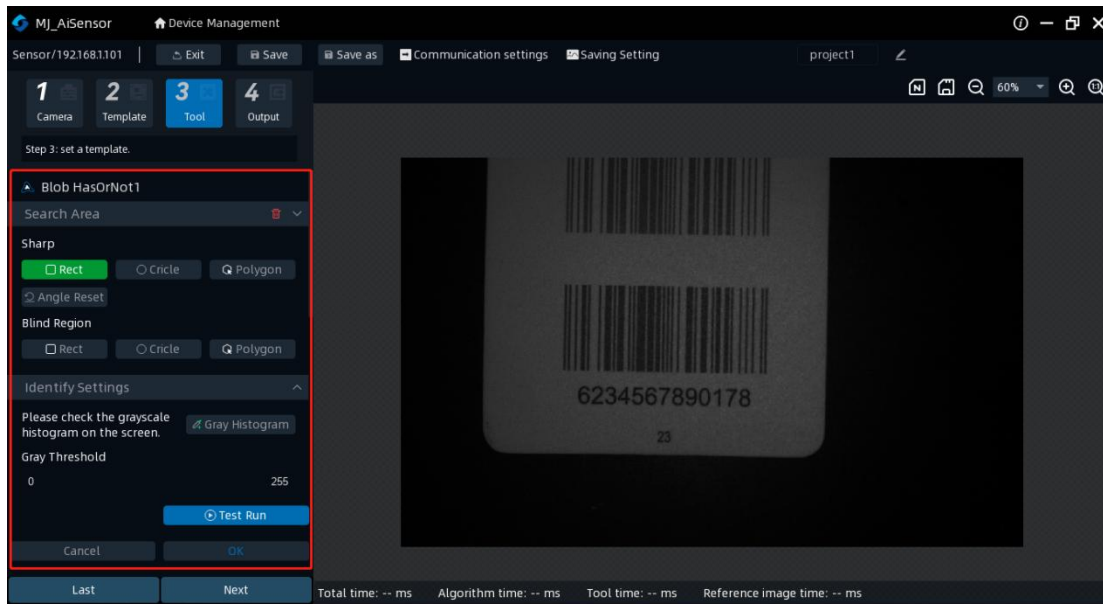

5.2.3.3 Count tools

Pattern count: Count the number of extracted color blocks (brightness blocks) within the set area. Set a threshold for the quantity to judge the similarity. OK: Calculate the number of shape pattern collections within the set area range. NG: Number less than the set area and size less than the set area.

Image counting tools are divided into: search area, adjust contour, and adjustment threshold

Search area: delimit the rectangular box and circle box in the search area, and click "rectangle" or "Circle" to search for the designated area in the preview window

Adjust the outline: the outline is divided into low, middle and third grade. Sliding the coordinate horizontal axis to adjust the contour sensitivity

Adjustment threshold: adjustable similarity

Number of patterns: the number of adjustable patterns. The minimum value is 1, and the maximum value is 10

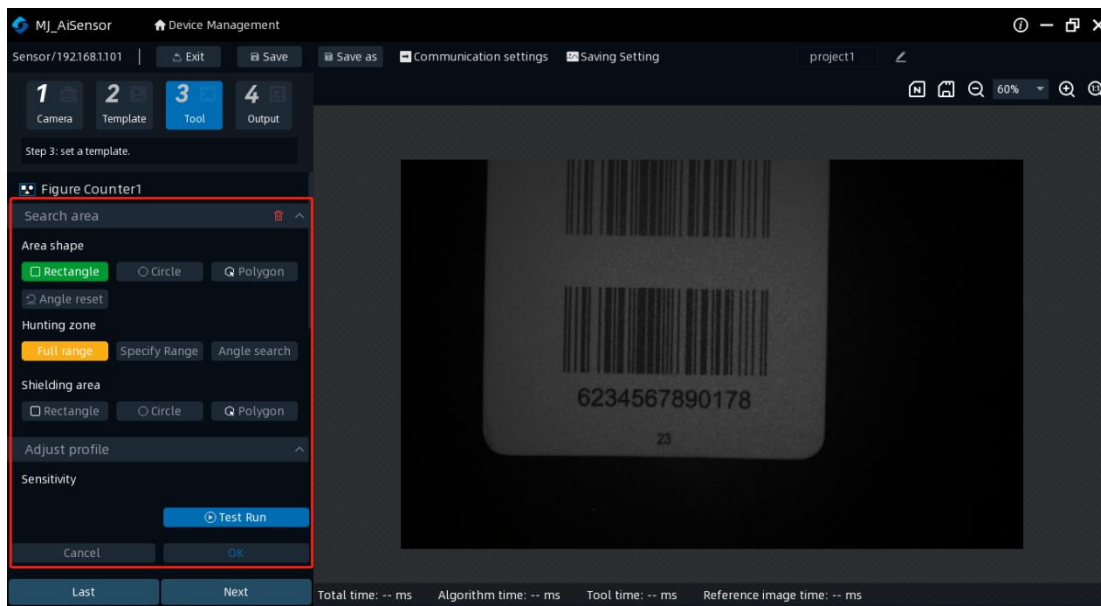

Spot count: Count the number of extracted color blocks (brightness blocks) in the set area. Set a threshold for the quantity to judge the similarity. OK: Calculate the number of block pattern collections within the set area range. NG: Number less than the set area and size less than the set area.

Search area: delimit the rectangular box and circle box in the search area, and click "rectangle" or "Circle" to search for the designated area in the preview window

Identification setting: Determine the gray scale threshold through the identification setting. The adjustment interval was all adjustable in the 0 – 255 range

Filter tool: it can be adjusted in the range of 0-1000,000

Number of patterns: the number of adjustable patterns. The minimum value is 1, and the maximum value is 10

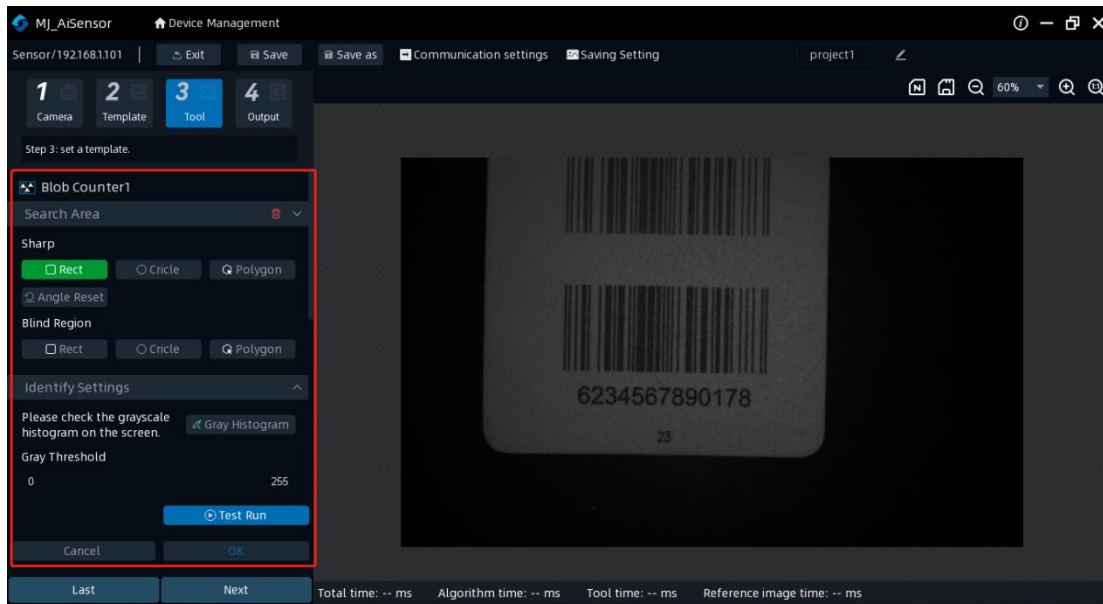

5.2.4IO output

Configure the output-related parameters of the templates and tools within the protocol

IO output is divided into three ways: IO 1, IO 2 and IO 3

Duration: minimum to 0, maximum to 100. Delay time: minimum to 0, maximum to 100

Effective level: normally open / closed

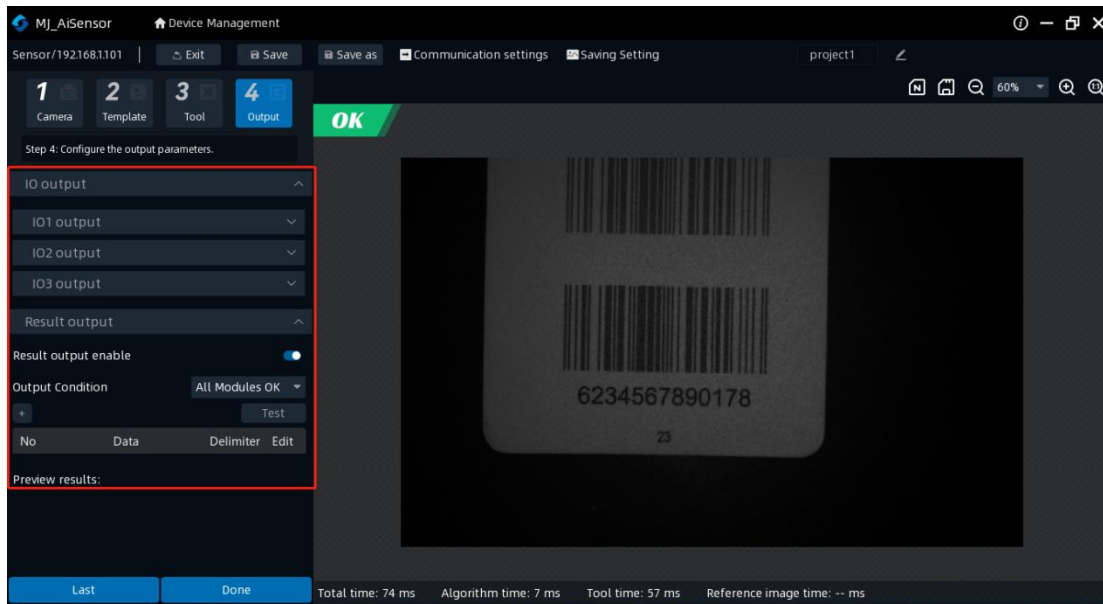

5.3 Scheme management

5.3.1 Scheme operation

Data reset: empty the data that can be identified, including the total number, NG, NG rate

List of tools: Click "Adjust the threshold" and slide the coordinate horizontal axis to adjust the threshold parameters

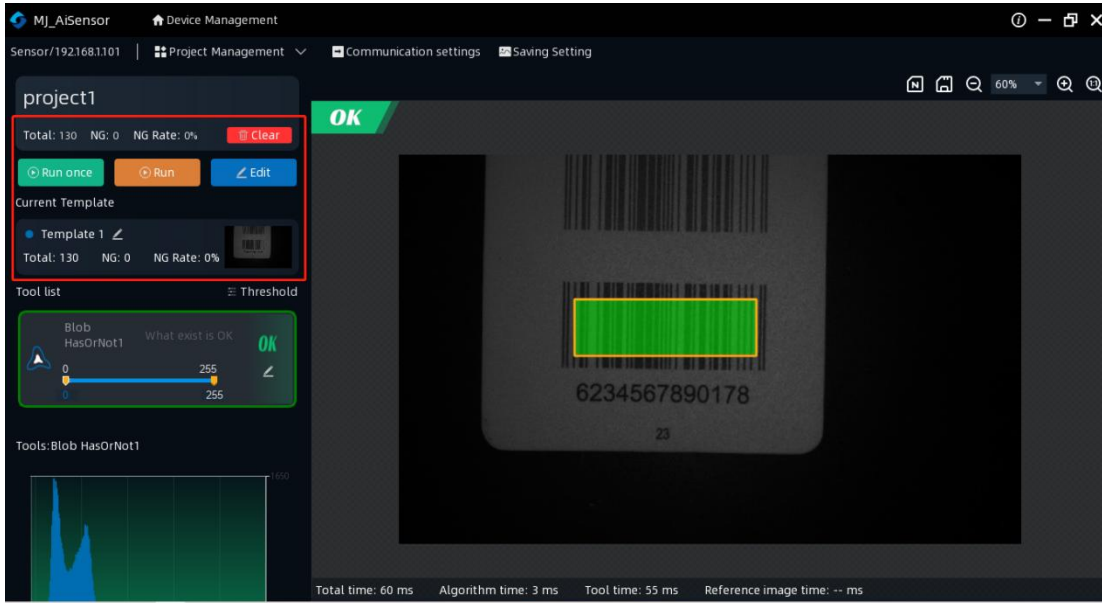

5.3.2 Scheme switching



Export the scheme, you can export the program to the computer



Copy the scheme, you can copy one more layer scheme to the software interface



Remove the current scheme



Edit the current scheme

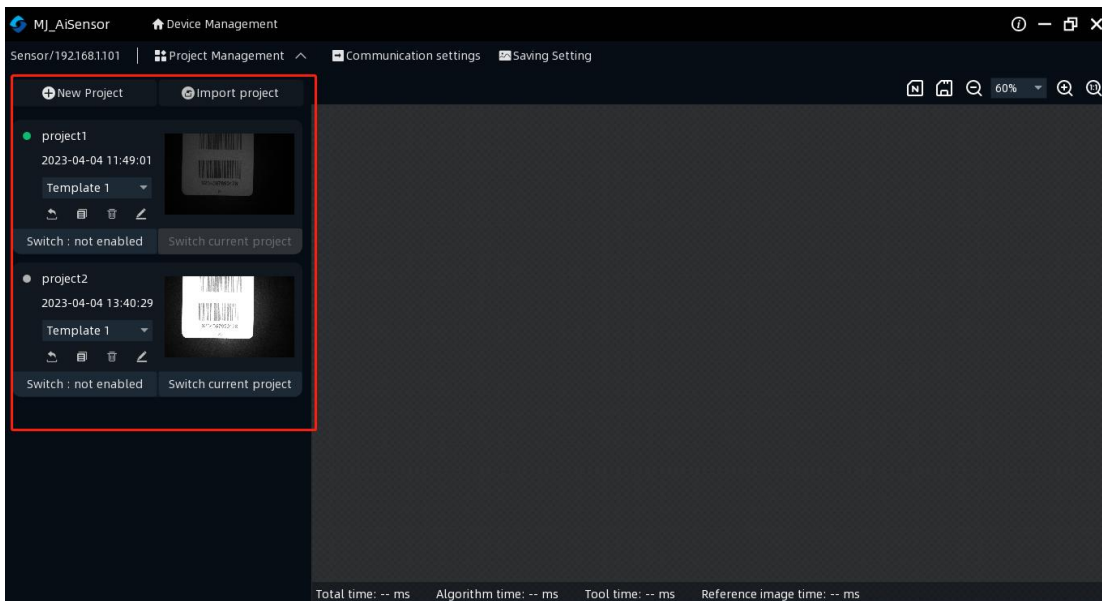

Chapter 6 List of FAQ

6.1 Client software identified the device but showed "inaccessible"

- **probable cause:**

1) The IP of the device and the network card connected to the device are not in the same network segment.

2) The network card has acquired the IP of two different segments.

- **resolvent:**

1) By modifying the device IP mode, make the computer and the device in the same network segment.

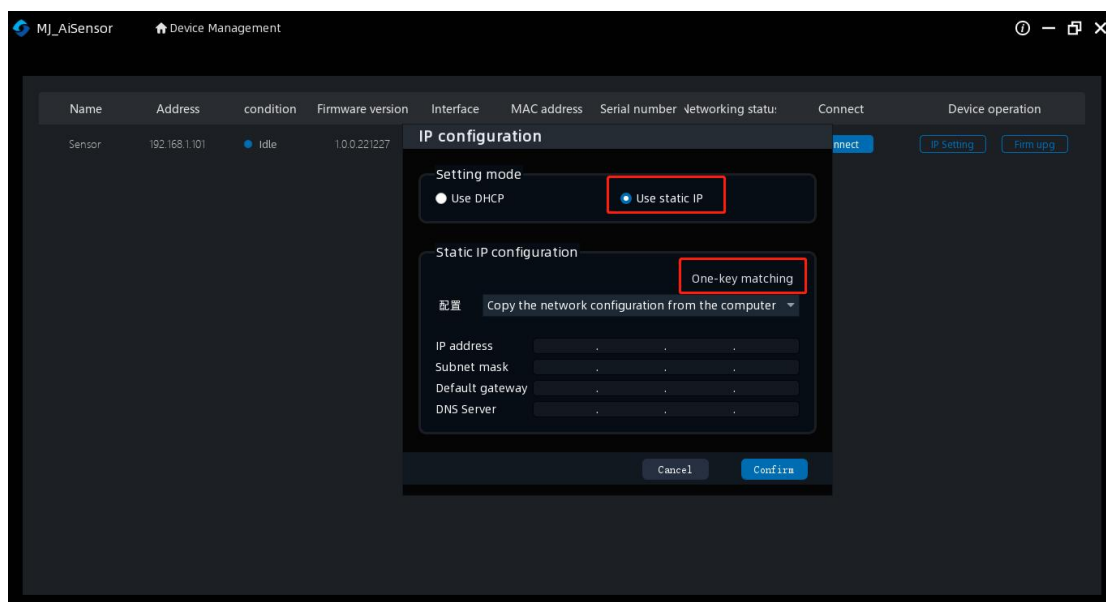

3) Click the computer "Start" -search box enter "cmd" -right click administrator permission to run-input: netsh winsock reset, reset the network card information, restart the computer.